



PC5005

Dual 10GbE port card for PCIe/104 and PCI/104-Express

Features:

- ★ Dual 10GbE ports on a PCIe/104 or PCI/104 Express platform
- ★ Meets PCI/104-Express & PCIe/104 Specification Version 2.10
- ★ PCIe/104 Type 1 Connector pinout
- ★ Standard PCIe/104 Form factor (3.775" x 3.550")
- ★ Configured as a single x8 PCIe Generation 3 lane (8 GT/s)
- ★ Power-driven by Intel's XL710 Ethernet Controller
- ★ Stack up or stack down flexibility
- ★ 10GbE ports support SFP+ transceivers
- ★ 2 independent 10GbE channels
- ★ Supports Jumbo Frames (9728 bytes)
- ★ 64-bit Addressing
- ★ Enhanced Network Security Features
- ★ Air-Cooled and Rugged, Conduction-Cooled available
- ★ Rigel's Standard 3 Year Warranty

Rigel's PC5005 Dual 10GbE card addresses the next generation high-speed connectivity and network security requirements for PCIe/104 and PCI/104-Express systems. The PC5005 provides exceptional small packet performance, advanced network security and reliability while the low-power adapter's TDP is 8W (typical).

The PC5005 features Intel's next generation 10GbE controller XL710. The XL710 interfaces to the host processor through a single x8 lane PCI Express generation 3 port. It will auto-negotiate to a reduced number of PCIe lanes if necessary. The XL710 controller is capable of auto-negotiating down to x4 or x1 PCIe lanes.

The XL710 employs the latest in Intel's Virtualization Technology for Connectivity (VT-c) such as On-Chip QoS and Traffic Management, Flexible Port Partitioning, Virtual Machine Device Queues (VMDq) and PCI-SIG* SR-IOV Capable.

The PC5005's flexibility and state of the art design make it ideal for high-speed peer-to-peer communication applications among many others that require blazing performance.

Contact our experienced engineering team to learn more about the PC5005.

Hardware Specifications

PCIe Host Interface

- ★ PCIe Gen 3 (8GT/s)
- ★ Single x8 default PCIe configuration
- ★ PCIe Base Specification Rev 3.0
- ★ 100MHz PCIe Frequency
- ★ Port widths of x8, x4 & x1

Ethernet

- ★ One Intel XL710 Dual Port controller
- ★ 2 SFP+ pluggable interfaces

Memory

- ★ 32 Mbit Serial Flash for PXE image

Miscellaneous

- ★ All power good LED
- ★ 4 Ethernet LEDs, speed & Activity per Port
- ★ Various software driver support

Physical / Electrical / Environmental

- ★ Standard PCIe/104 form factor (3.775" x 3.550")
- ★ 2.7 oz / 77 grams (no SFP modules or heat sink)
- ★ +5V Maximum / typical power : 1.6A / 1.2A
- ★ Temperature:
 - Operating (standard) : 0°C to +70°C
 - Storage : -40°C to +85°C
- ★ Relative Humidity:
 - Operating: 5% to 95%, non-condensing
 - Storage: 5% to 95%, non-condensing

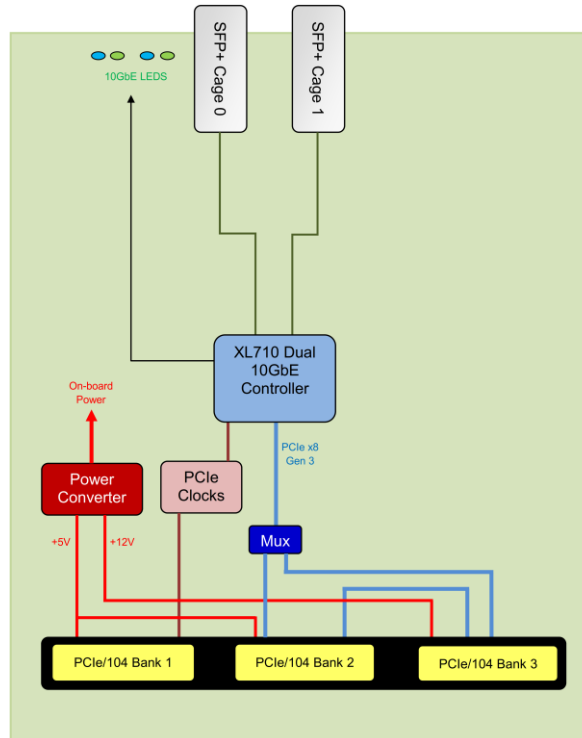

Ordering Information

Base Model	_____	PC5005-xx00
Operating Temperature & Cooling Options	_____	
0 = 0°C to +70°C, Air Cooled 1 = -40°C to +85°C, Air Cooled 2 = -40°C to +85°C, Conduction Cooled Z = Customer specific board configuration		
PC104 Type	_____	
0 = PCI/104-Express (With PCI Connector) 1 = PCIe/104 (Without PCI Connector)		
Reserved	_____	
Reserved	_____	

At Rigel Engineering, we are dedicated to working directly with your Engineers and System Designers to provide the best possible solution that meets or exceeds your requirements.

Custom solutions with off-the-shelf pricing